

# Bassani® Xhaust

## **BASSANI LONG TUBE RACE HEADERS**

**PART #5091R**

**OFF ROAD\*\*\* USE ONLY**

Please take a few minutes to read these instructions before beginning the installation.  
If you feel that you cannot perform this installation after reading the instructions,  
please take your vehicle to a dealer or qualified service shop in your area.

### **TOOLS REQUIRED**

Sockets-7/16", 1/2", 9/16", 5/8", 11/16" Deep or Shallow  
Screwdriver- Straight blade  
Wrenches- 7/16", 1/2", 9/16", 11/16"  
Ratchet- 3/8" Drive  
Extension - about 10"  
Universal - 3/8 Drive

### **ADDITIONAL TOOLS RECOMMENDED**

Ratchet - 1/4" Drive  
Extension - 3" to 6"  
Universal - 1/4" Drive

### **BASSANI RACE HEADERS PARTS LIST**

1. 8 Header Tubes
2. 2 pcs. 4 into 1 Collectors
3. 1 Pair of Exhaust Gaskets
4. 16 Header Bolts- 3/8 -16 X 1" Long (Black)
5. 4 - 1/4" X 1/2" Long Button Head Allen Bolts
6. 4 -1/4" Nylock Nuts
7. 2 Tubes of *Bassani* Anti Seize Jet Lube
8. 4 Plastic Wire Ties
9. Instructions

### **INSTALLATION INSTRUCTIONS**

- Headers are 1 3/4" primary tubes stepped to 1 7/8" tubes. They fit both manual 5 speed and A.O.D. transmissions.
- Use *BASSANI* Jet Lube for installation of header bolts, 4 into 1 collectors, and sensors. This will ease installation and removal later on.
- With a manual transmission, the stock starter may be used. Use of a \*mini hi-torque starter is recommended, however with an A.O.D. transmission, you must use the \*mini-torque starter.
- O<sup>2</sup> sensor leads must be re-routed to allow sufficient length to reach header O<sup>2</sup> bosses. Factory wire ties must be cut to achieve this. Reattach the leads with provided wire ties. DO NOT allow spark plug wires to contact exhaust tubes! They will burn.

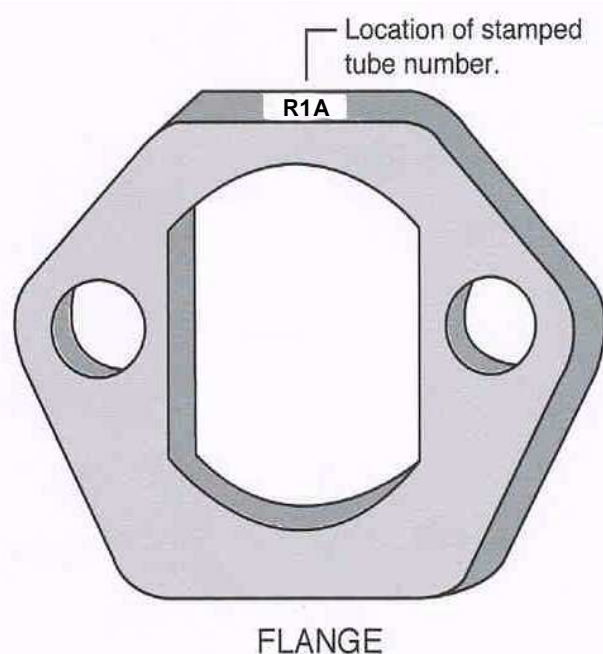

## Part #5091R Instructions Continued

### RIGHT SIDE INSTALLATION (See illustration)

1. Make sure the cylinder head surface is clean and free of all old gasket material.
2. Attach a new gasket to the cylinder head first, or install the first and last header bolts loosely and hook the gaskets in place.
3. Install tube #4 from under the car. Install bolts loosely. (Tube # is stamped on the flange.)
4. Install tube #3 from under the car. Install bolts loosely.
5. Install tube #2 from under the car. Do not install bolts.
6. Install tube #1 from under the car. Do not install bolts.
7. Install bolts on tube #1 and #2, then hand tighten all header bolts.
8. Slide the 4 into 1 collector onto the header tubes from under the car. Install the ¼" X ½" long Allen bolts and nylock nuts into the collector tabs loosely.
9. Evenly tighten all right side header bolts at this time. Also, tighten the two ¼" Allen bolts in the collector tabs.

### LEFT SIDE INSTALLATION (See illustration)

1. Make sure the cylinder head surface is clean and free of all old gasket material.
2. Attach a new gasket to the cylinder head first, or install the first and last header bolts loosely and hook the gaskets in place.
3. Install tube #8 from under the car. Install bolts loosely.
4. Install tube #7 from under the car. Install bolts loosely.
5. Install tube #5 from the top of the car. Install bolts loosely.
6. Install tube #6 from the top of the car. Install bolts loosely.
7. Install bolts on tube #5 loosely, then tighten all header bolts by hand.
8. Slide the 4 into 1 collector onto the header tubes from under the car. Install the ¼" X ½" long Allen bolts and nylock nuts into the collector tabs loosely.
9. Evenly tighten all left side header bolts at this time. Also, tighten the two ¼" Allen bolts in the collector tabs.

**Note:** Recheck the tightness of all header hardware after one day of operation to ensure correct torque.

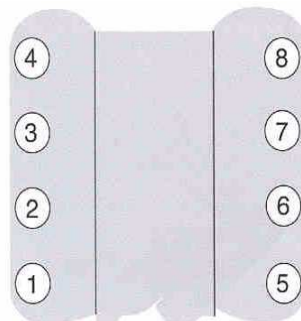

FRONT

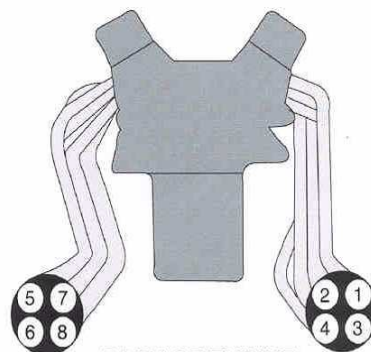

BACK OF ENGINE

\*\*\* "Legal in California for racing vehicles which may never be used upon a highway."

\* Installation verified with FMS starter, part number M-1100-A50

5091R LongTubes.doc 11/19/01

2900 E. La Jolla Street, Anaheim, CA 92806 (714) 630-1821 Fax (714) 630-2980